

ALUMINUM ACCESSORIES

SPECIFICATIONS

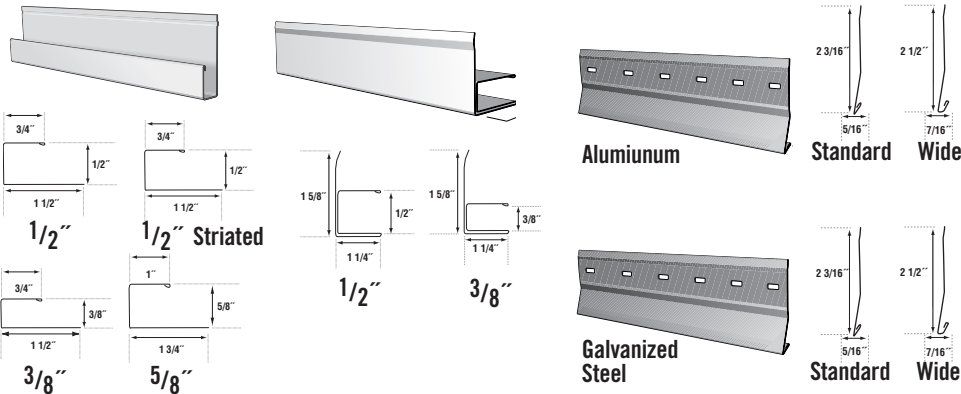

J-CHANNEL

F-CHANNEL

STARTER STRIP

Physical Characteristics and Manufacturing Data:

Coating	Two-coat Waterbase Acrylic	Premium PVC Coated Finish
Gloss:	10-14 @ 60°, ASTM D 523-80	22-27 @ 60°, ASTM D 523-80
Flexibility:	No removal of finish with 600 Scotch Tape on a 2T bend. NCCA 11-19	No removal of finish with 600 Scotch Tape on a 1T bend. NCCA 11-19
Pencil Hardness:	HB-H, Eagle Turquoise. NCCA 11-12	2B, Eagle Turquoise. NCCA 11-12
Adhesion:	Excellent, ASTM D 3359-83	Excellent, ASTM D 3359-83
Impact:	No visual cracking or finish release when subjected to impact in inch pounds equal to one and one-half times the metal thickness. NCCA 11-6	No visual cracking or finish release when subjected to impact in inch pounds equal to one and one-half times the metal thickness. NCCA 11-6
Humidity Resistance:	No loss of gloss, cracking or peeling after 3,000 hours @ 100% relative humidity. ASTM D 2247-86A	No loss of gloss, cracking or peeling after 3,000 hours @ 100% relative humidity. ASTM D 2247-86A
Salt Spray Resistance:	No under-cutting of film from edges in excess of 1/16" or face blistering after 3,000 hours @ 5% neutral salt spray. ASTM B 117-85	No under-cutting of film from edges in excess of 1/16" or face blistering after 1,000 hours @ 5% neutral salt spray. ASTM B 117-85
Exterior Exposure:	a. Fade: Max. #5 after 10 years at 45° south Florida exposure after removal of external deposits. ASTM D 2244-85 b. Chalk: Max. #8 rating on all colors with the exception of White within 10 years at 45° south Florida exposure. ASTM D 659-86	a. Fade: Max. #5 after 10 years at 45° south Florida exposure after removal of external deposits. ASTM D 2244-85 b. Chalk: Max. #8 rating on all colors with the exception of White within 10 years at 45° south Florida exposure. ASTM D 659-86
Dry Film Thickness:	.90 - 1.00 mils	3.3 - 3.7 mil
Solvent Resistance:	100+MEK rubs Meets the performance requirements of AAMA 1402-86	MEK rubs - none Meets the performance requirements of AAMA 1402-86

Packaging: J-Channel packaged 25 pieces, 12'0" long, 300 feet. Approximately 19 lbs./carton
 F-Channel packaged 25 pieces, 12'0" long, 300 feet. Approximately 37 lbs./carton
 Durabuilt F-Channel packaged 25 pieces, 12'0" long, 300 feet. Approximately 20 lbs./carton
 Aluminum Starter Strip (Standard) packaged 50 pieces, 10'0" long, 500 feet. Approximately 26 lbs./carton
 Aluminum Starter Strip (Wide Hem) packaged 50 pieces, 10'0" long, 500 feet. Approximately 31 lbs./carton
 Galvanized Steel Starter Strip (Standard) packaged 25 pieces, 10'0" long, 250 feet. Approximately 50 lbs./carton
 Galvanized Steel Starter Strip (Standard) packaged 25 pieces, 10'0" long, 250 feet. Approximately 59 lbs./carton

Product Information: 3/8" J-Channel for use with Triple 4 Soffit and Quad 4 Soffit. 1/2" J-Channel for use with Double 6 Soffit. (also available in PVC finish)
 3/8" F-Channel for use with Triple 4 Soffit and Quad 4 Soffit.
 1/2" F-Channel for use with Double 6 Soffit.



VINYL & METAL EXTERIOR PRODUCTS

by PLY GEM

2600 Grand Boulevard Ste 900, Kansas City, MO 64108
 Phone: 800-78-NAPCO, Fax: 888-842-3991
 www.napcoproducts.com

